

Clarke®



WARNING: Do not use the machine without reading this manual

PETROL DRIVEN POWER WASHER

MODEL NO: TIGER 2600B

PART NO: 7320207

OPERATION & MAINTENANCE INSTRUCTIONS

UK
CA | CE

ORIGINAL INSTRUCTIONS

DL0923 Rev 1

INTRODUCTION

Thank you for purchasing this CLARKE Petrol driven power washer.

Before attempting to use this product, please read this manual thoroughly and follow the instructions carefully. In doing so you will ensure the safety of yourself and that of others around you, and you can look forward to your purchase giving you long and satisfactory service.

GUARANTEE

This product is guaranteed against faulty manufacture for a period of 12 months from the date of purchase. Please keep your receipt which will be required as proof of purchase.

This guarantee is invalid if the product is tampered with in any way, or not used for the purpose for which it was intended.

Faulty goods should be returned to their place of purchase, no product can be returned to us without prior permission. This guarantee does not effect your statutory rights.

ENVIRONMENTAL RECYCLING POLICY

One of the most damaging sources of environmental pollution is oil products. Never throw away used oil with domestic refuse or flush it down a sink or drain. Collect any oil in a leak proof container and take it to your local waste disposal site.

Should any components become completely unserviceable and require disposal, plastic and metal components should be disposed for re-cycling according to local regulations.

GENERAL SAFETY RULES



WARNING: WATER AT HIGH PRESSURE CAN BE DANGEROUS AND CAN CAUSE DAMAGE IF THE OPERATOR IS CARELESS. DO NOT LET PERSONNEL OPERATE THIS PRESSURE WASHER UNLESS THEY ARE KNOW THE SAFETY PRECAUTIONS.

1. **DO NOT** point the spray at other people, animals, electrical equipment or the machine itself.
2. **DO NOT** hold your finger over the high pressure nozzle.
3. **DO NOT** let children or untrained personnel use this machine.
4. **DO NOT** operate the machine with any of the covers removed.
5. **DO NOT** try to repair this machine. Always refer to your CLARKE service department for all repairs.
6. **DO NOT** supply any liquid other than water to the water inlet.
7. **DO NOT** use the detergent pickup facility to introduce flammable liquids/ solvents, e.g. paint thinners, petrol, oil as there is a risk of explosion.
8. **ALWAYS** release the remaining pressure in the system; turn off the water supply and operate the trigger before you remove hoses or accessories.
9. **ALWAYS** keep the machine dry and away from the water spray.
10. **ALWAYS** use protective clothing and safety glasses. Loose particles and other items can be propelled at high speed by the water spray.
11. **ALWAYS** hold the gun securely & expect it to 'kick' when the trigger is pulled
12. **ALWAYS** respect the requirements of the local water company. Pressure washers may only be connected to the mains water supply if a system separator (known as a backflow preventer) is installed in the supply hose.
13. **ALWAYS** disconnect from the water supply, and make sure that you drain the system when not in use. Keep in a cool dry location.
14. **ONLY** use detergents that are suitable for pressure washers, we recommend that you use CLARKE Traffic Film Remover or CLARKE Wash and Wax (available from your dealer).
15. **WARNING** High pressure water jets can be dangerous, the jet must not be directed at a person or anything that they are wearing.
16. **WARNING** High pressure hoses, fittings and couplings are important for the safety of the machine. Use only hoses, fittings and couplings recommended by the manufacturer.
17. **WARNING** Water that passes through a system separator (also known as a backflow preventer) is not safe to drink.
18. **DO NOT** use the pressure washer if there is damage to the inlet/outer hose.

SAFETY SYMBOLS

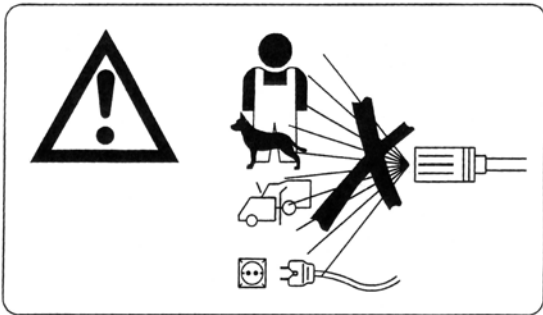

WARNING: Do not direct discharge stream at persons or animals. Keep clear of nozzle.

WARNING: Never direct spray toward any electrical device or electrical outlet.



General Warning, indicates that failing to follow these instruction could result in injury or damage to the machine.



To reduce the risk of injury, read the manual before use.



ALWAYS wear safety glasses when using this machine.



WARNING: No open flame, open ignition source and smoking is prohibited



WARNING: No smoking



DANGER: Risk to breathing. Engine exhaust fumes can kill. For outdoor use only. Work in a well ventilated area.



WARNING: Risk of injection or severe injury. Do not direct discharge stream at persons or animals. Keep clear of nozzle. This machine is to be used only by qualified operators.

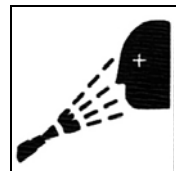

WARNING: Risk of spray injury. Spray can propel objects. Always wear ANSI approved Z87.1 Safety Glasses.



WARNING: Risk of chemical burn. Never spray acids, corrosive or toxic chemicals. Use only cleaners formulated for pressure washers.



WARNING: Risk of electrocution. Never direct spray toward any electrical device or electrical outlet.



WARNING: Risk of unsafe operation. Keep children away from this equipment. Gun kicks back. Hold with both hands.



WARNING: Risk of hot surfaces.

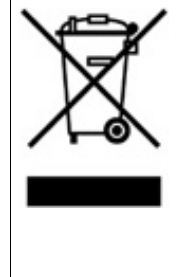

Recycle unwanted materials instead of disposing of them as waste. All tools, accessories and packaging should be sorted, taken to a recycling centre and disposed of in a manner which is compatible with the environment.

OVERVIEW



NO	DESCRIPTION	NO	DESCRIPTION
1	Fuel Tank Cap	11	Engine On/Off Switch
2	Fuel Tank	12	Oil Filler Cap
3	Spark Plug	13	Water Outlet
4	Choke	14	Detergent Tank
5	Gun Assembly	15	Water Inlet
6	Lance Assembly	16	Bypass Drain Hose
7	Air Filter Cover	17	Hose Holder
8	Recoil Pull Start	18	Lance Holder
9	Fuel Valve	19	Priming Bottle
10	Throttle		

UNPACKING AND ASSEMBLY

Unpack your pressure washer and make sure that the following items are present. Contact your CLARKE dealer immediately if any parts are missing or damaged.

- 1 x Petrol Power Washer
- 2 x Wheel c/w Axle
- 1 x Upper Handle c/w fixings
- 1 x Hose Bracket c/w fixings
- 1 x Lance Bracket c/w fixings
- 1 x Primer Bottle
- 1 x Primer Bottle Bracket
- 1 x Hose
- 1 x Water Filter (may be supplied already fitted)
- 1 x Gun Assembly
- 1 x Lance / Nozzle Assembly
- 1 x Spark Plug Box Spanner
- 1 x Tommy bar
- 1 x Engine Manual
- 1 x Primer Bottle Holder
- 2 x Rubber feet and fixings
- 1 x 3m Inlet water hose

CONNECTING THE WHEELS

1. Slide the axles into the locating tube as shown.
 - Make sure the ball catch locks into the small hole on the bottom of the locating tube.

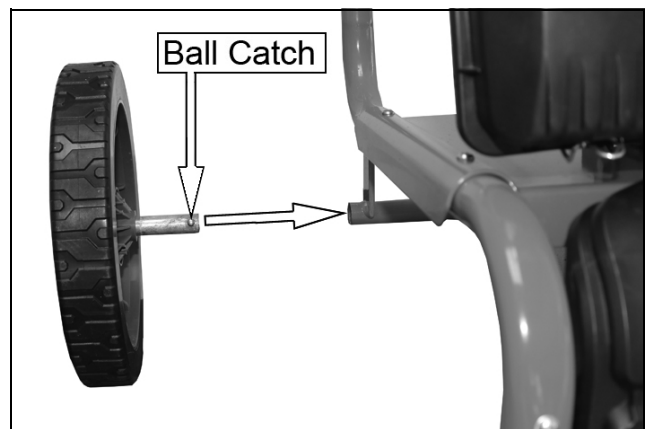

2. Add the 2 axle covers as shown.

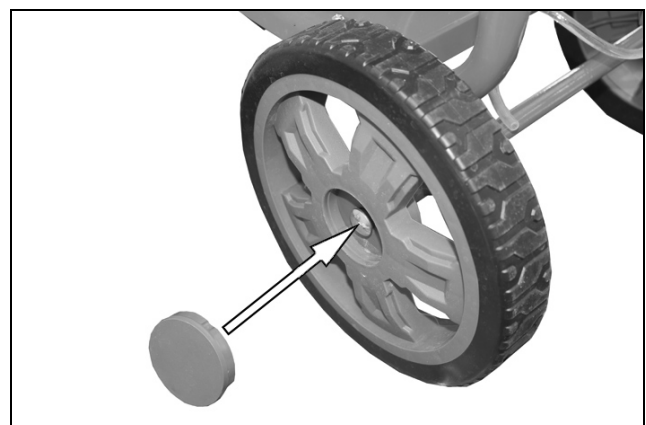

CONNECTING THE HANDLE

1. Slide the upper handle into position as shown.
2. Secure using a bolt and handwheel.
 - The handwheel should be on the outside.

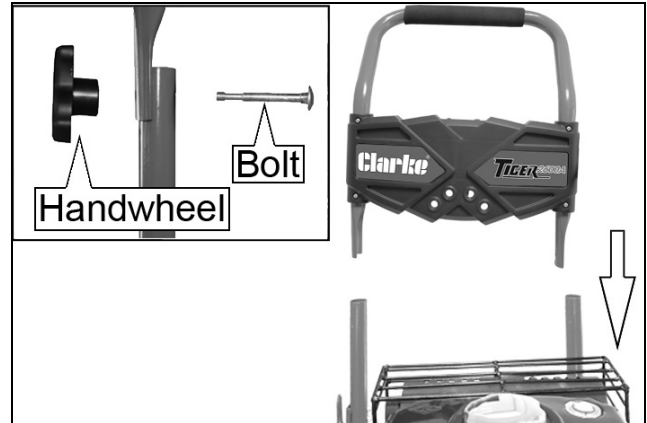

FITTING THE WATER BOTTLE

NOTE: The water bottle is only used when using the drawing water from an unpressurised source such as a water butt. See page 16.

1. Fit the bracket to the frame as shown using the bolts, nuts and washers supplied.
2. Slide the bottle holder over the bracket and place the bottle in the holder.

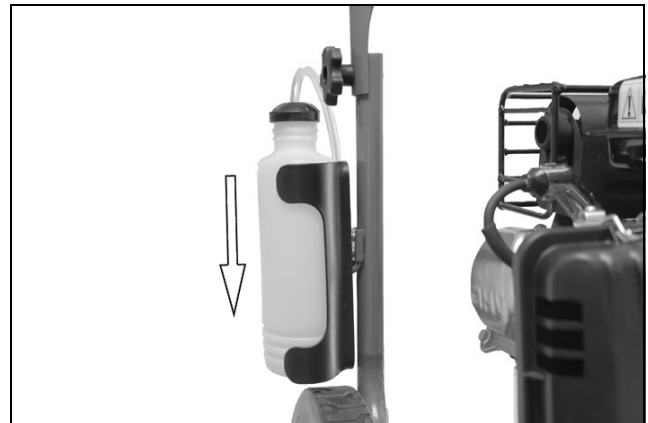
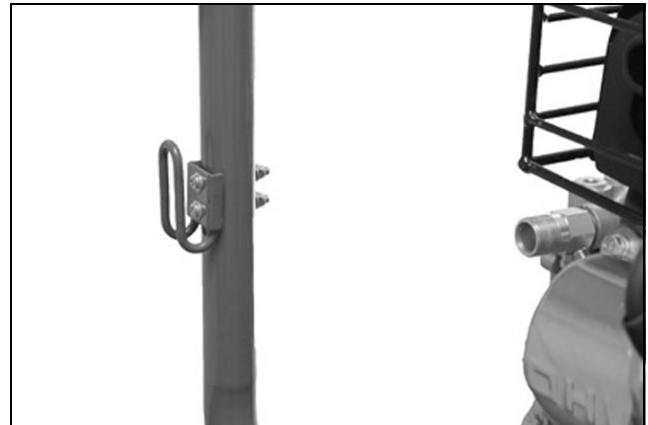

FITTING THE LANCE/HOSE HOLDER

Fit the holders into the positions shown and secure using the washers and nuts provided.

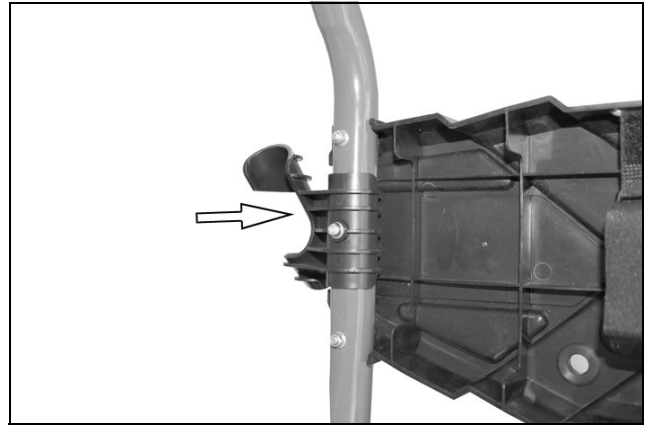

CONNECTING THE HIGH PRESSURE HOSE

CONNECT THE HOSE TO THE GUN

1. Screw the high pressure hose onto the gun assembly.
 - Tighten the connector, hand tight only. Do not use a spanner.

NOTE: Make sure the connection is secure.

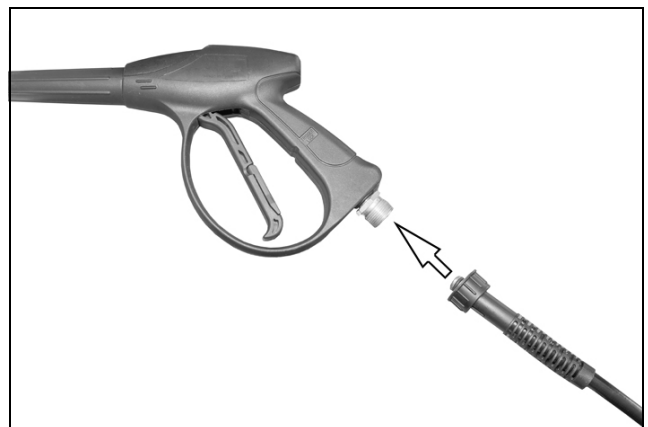

CONNECT THE HOSE TO THE PRESSURE WASHER

1. Screw the hose on to the pressure washer.
 - Tighten the connector, hand tight only, Do not use a spanner.

NOTE: Make sure the connection is secure.

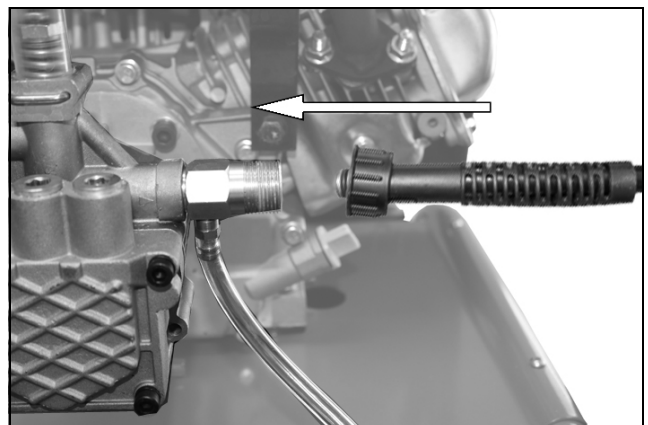

ASSEMBLING THE LANCE

Connect the spray lance to the gun assembly and tighten securely by turning the locking ring.

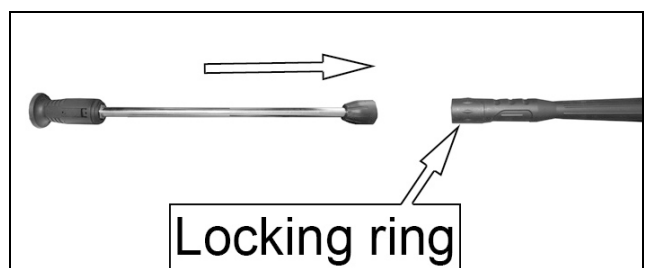

CONNECTING THE WATER SUPPLY

Always follow the regulations of your local water supplier. The pressure washer must never be connected to the drinking water supply without using a system separator (also known as a backflow preventer) available from most hardware stores.

NOTE: Water that has flowed through a system separator is considered non-drinkable.

1. Connect a water supply hose (not supplied) to the water inlet.
 - Make sure that the water filter is installed behind the hose connector on the water inlet

NOTE: Use a good quality fibre reinforced water hose with a standard coupling.

NOTE: This machine has the ability to draw its own water, meaning you can use water not under pressure such as rainwater collected in a water butt. See page 16.

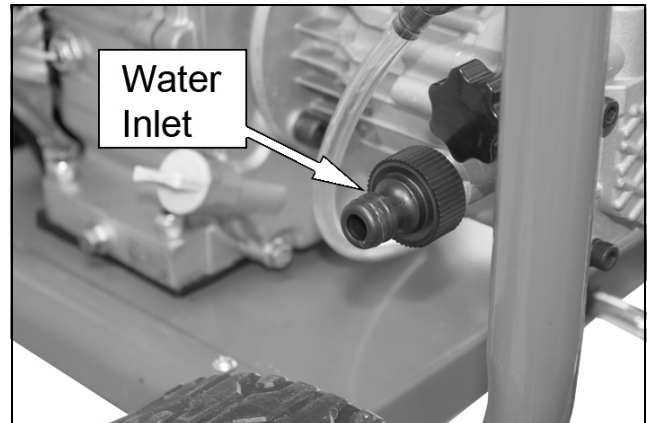

BEFORE USE



WARNING: STAND THE PRESSURE WASHER ON LEVEL GROUND WITH THE ENGINE SWITCHED OFF.

WARNING: TAKE CARE NOT TO TOUCH ANY HOT PARTS OF THE PRESSURE WASHER WHEN CHECKING THE OIL LEVEL.

WARNING: REFUEL IN A WELL-VENTILATED AREA, AWAY FROM ANY SOURCES OF IGNITION.

WARNING: IF THE ENGINE HAS BEEN RUNNING, ALLOW IT TO COOL BEFORE REFUELING.

WARNING: DO NOT LEAVE FUEL WITHIN THE REACH OF CHILDREN.

WARNING: REFUEL CAREFULLY TO AVOID SPILLING FUEL.

IMPORTANT: The engine is supplied without any oil in it and must be filled to the correct level before use, see below.

ENGINE OIL

1. Turn the oil filler cap anticlockwise and remove it from the engine, wipe the integral dipstick with a clean cloth.
2. Insert the oil filler cap back into place and then remove it again.
3. If the oil reads low on the dipstick, add oil to the oil reservoir (Max 0.6L).
 - We recommend the use of SAE10W-30 oil.
 - Do not overfill the oil reservoir.
4. Replace the oil filler cap.

NOTE: Running the engine with insufficient oil will cause engine damage.

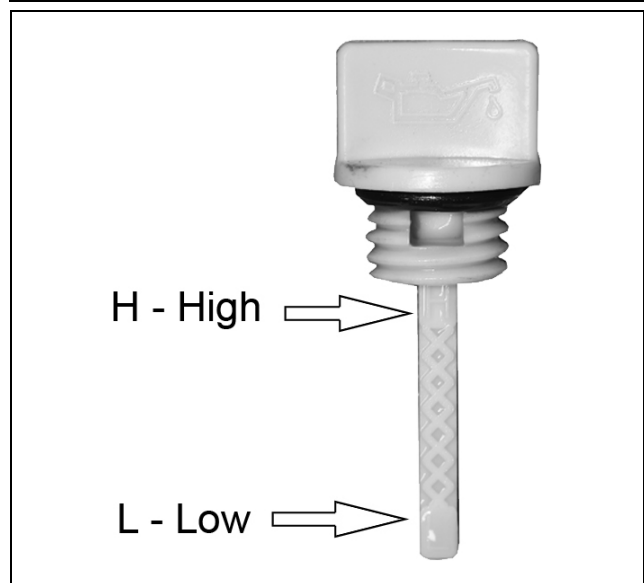
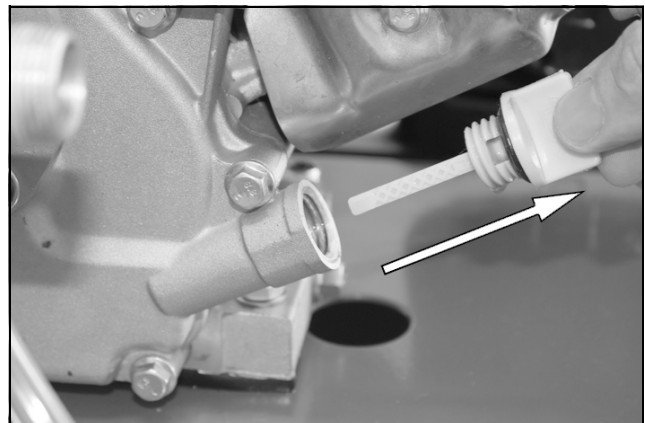

ADDING FUEL

1. Remove the fuel tank cap.
 - Just inside the fuel tank is a fuel strainer, which should be checked periodically and any contaminants which have accumulated must be removed.
2. Pour unleaded petrol through the fuel strainer and into the fuel tank.
 - Do not fill above the fuel strainer shoulder.
 - Use unleaded petrol with a pump octane rating of 86 or higher.
3. Replace the fuel filler cap securely.

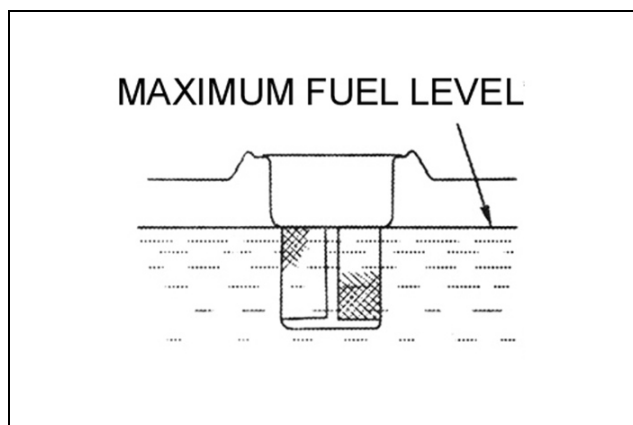

STARTING YOUR PRESSURE WASHER

1. Turn the water supply on, making sure that the tap is fully open.



WARNING: FAILURE TO TURN ON THE WATER COULD CAUSE DAMAGE TO THE PRESSURE WASHER.

2. Set the choke lever to the CLOSE position.

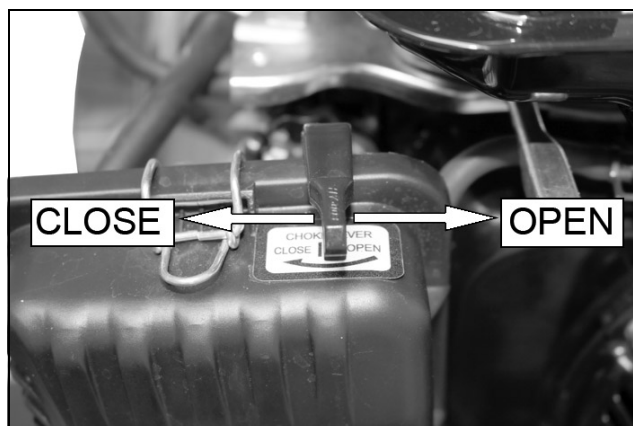

3. Set the fuel supply valve to the ON position.

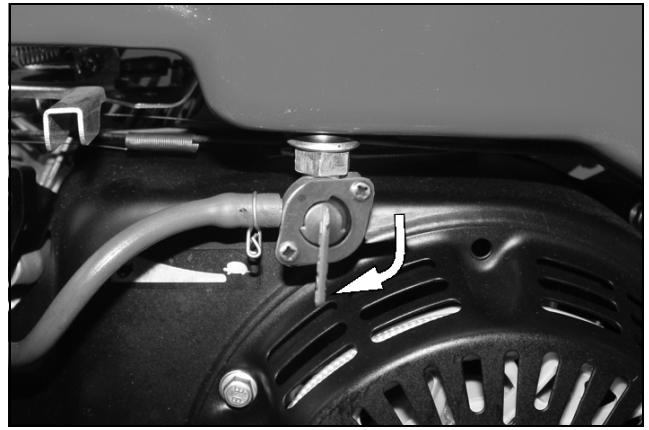

4. Slide the throttle lever to the left approximately 3/4 of the way.

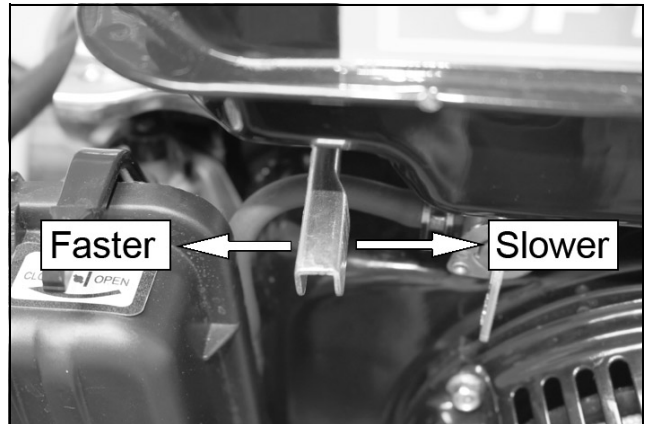

5. Set the engine switch to the on (I) position.

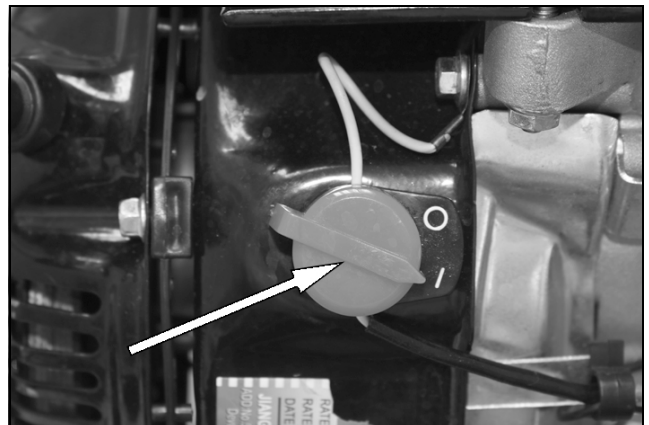

6. Pull the recoil starting handle lightly until you start to feel resistance and then pull up sharply to start the engine.

- You may have to do this more than once.

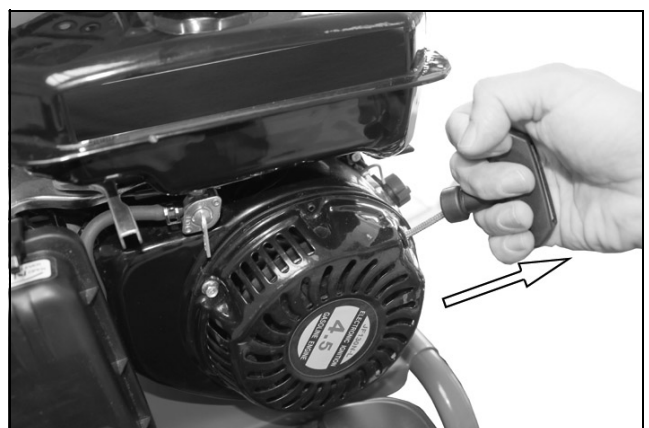



WARNING: ONCE THE PRESSURE WASHER ENGINE HAS STARTED, RELEASE THE STARTING HANDLE SLOWLY TO AVOID INJURY/DAMAGE AS IT RECOILS.

7. Once the engine has warmed up, slide the choke lever to the OPEN position.

- The pressure washer is now ready for use.

8. Release the trigger lock.

9. Ensuring that you have a firm footing and that you are also holding the gun assembly and spray lance firmly, pull the trigger on the gun to start water flow.

- The lance and gun will kick back when the trigger is first pulled.

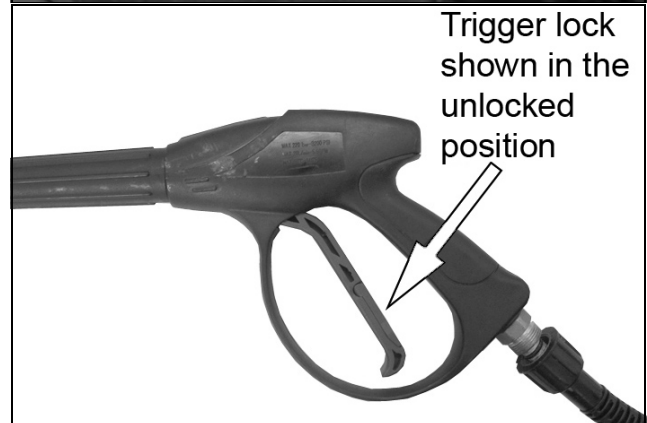
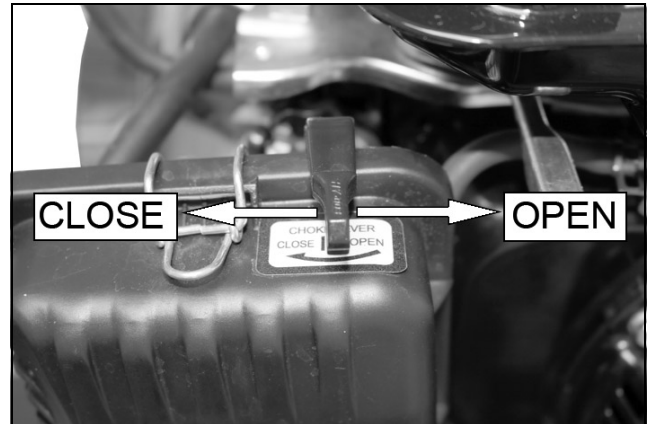

INTERRUPTING OPERATION

1. Release the trigger.

NOTE: The pressure washer will automatically go into bypass mode.

NOTE: If you notice water coming from the drain tube attached to the pump, please note that this is a safety feature and should be expected, it cools the pump by releasing some of the hot water within the pump and replacing it with fresh 'cool' water.

2. Rotate the trigger lock to the locked position.



ADJUSTING THE SPRAY NOZZLE

The nozzle is adjustable to allow you to adjust the water delivery from a narrow jet of water to a wide spray. To adjust the nozzle, proceed as follows:

1. Hold the shaft of the lance in one hand.
2. Twist the nozzle with the other hand.
 - The spray varies between narrow and wide as you turn the nozzle.

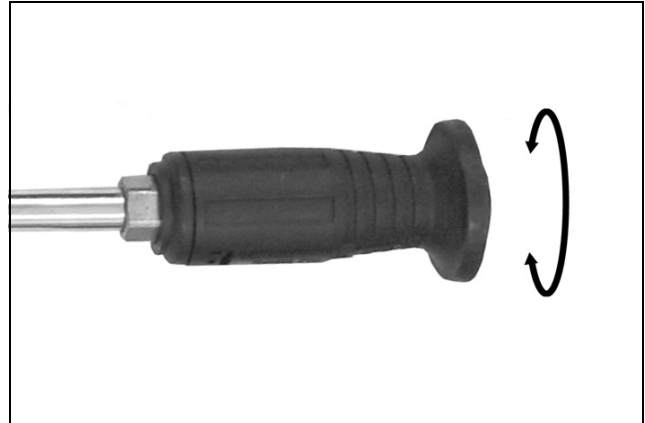

ADJUSTING THE PRESSURE

The machine output is preset at the factory. To lower the contact pressure:

1. Back away from the surface to be cleaned. The further away you are the less the pressure will be on the surface being cleaned.
2. Reduce the speed of the engine using the throttle. Slow the engine down and the water pressure will also go down.
3. Adjust the spray to a wider angle.
4. Hold the rear of the nozzle and slide the front of the nozzle forwards to low pressure and backwards for high pressure. See page 14.

APPLYING DETERGENTS AND CLEANING AGENTS

To improve the cleaning performance, you can introduce chemical cleaning agents (detergents) to the water jet using the detergent pickup hose.

1. Remove the detergent tank cap.
2. Fill the tank with a suitable CLARKE detergent and replace the cap.
 - Only use detergents recommended for use with pressure washers, such as CLARKE Traffic Film Remover which is a powerful low foaming agent for car cleaning, patio cleaning etc., or CLARKE Wash & Wax, both available from your CLARKE dealer.

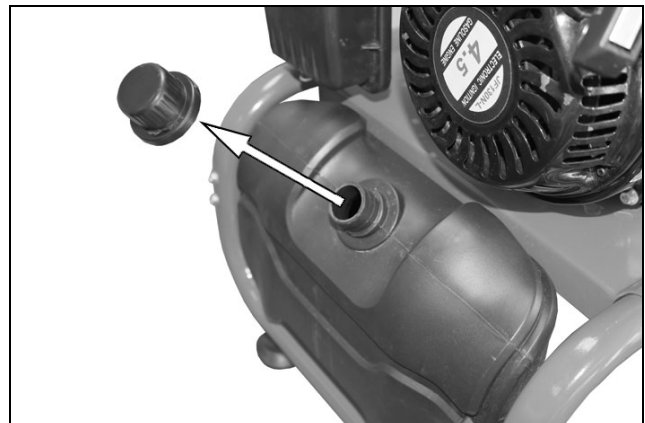

3. Hold the rear of the nozzle on the high pressure lance and slide the front of the nozzle forwards to low pressure.
4. Spray the detergent onto the vehicle, patio etc.
 - Allow the detergent a little time to work itself into the grime.

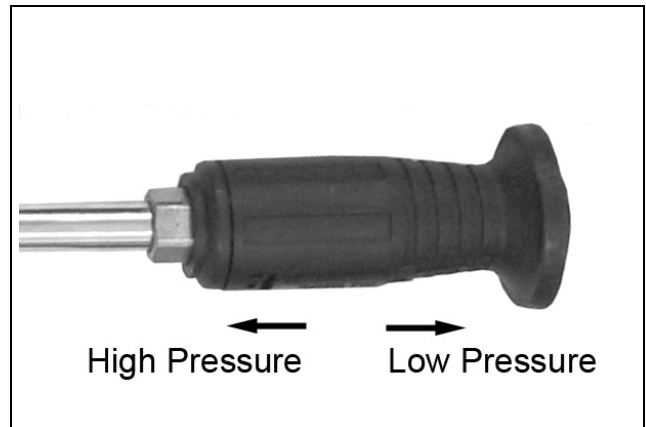

CAUTION: CAUTION: IF YOU GET CLEANING FLUID IN YOUR EYES, RINSE THEM IMMEDIATELY WITH PLENTY OF FRESH CLEAN WATER. AND SEEK MEDICAL ADVICE IF REQUIRED.

- To rinse, slide the front of the nozzle on the lance back towards the handle and use the pressure washer as normal.

SHUTTING DOWN

1. After each use, if you have applied chemicals, slide the front of the nozzle on the lance back towards the handle and operate the pressure washer for a short time to flush the hoses.
2. Move the throttle control lever to the right.
3. Turn off the engine switch, to the off (O) position.
4. Turn water supply off at the tap.
 - NEVER turn the water off with the engine running.
5. Release the pressure in the pump and hose by squeezing the trigger for a few seconds until no more water comes out of the nozzle.
6. Turn the fuel supply valve to the off position.

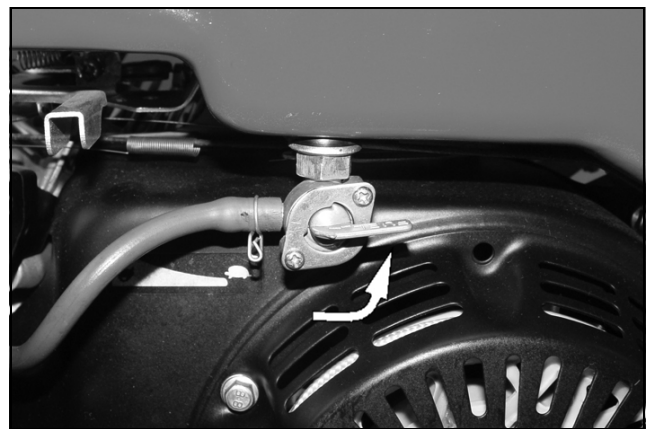
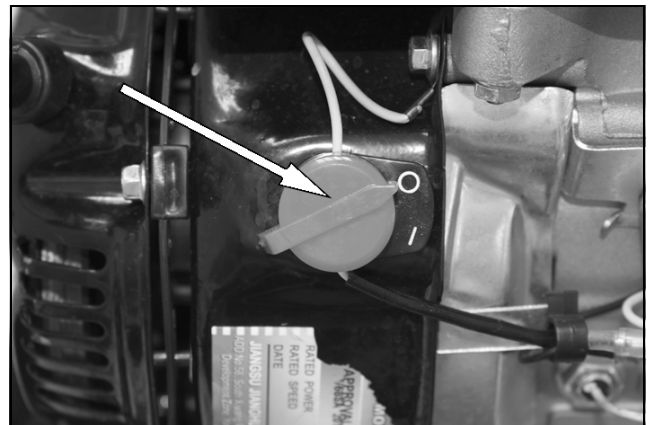

7. Rotate the trigger lock to the locked position.

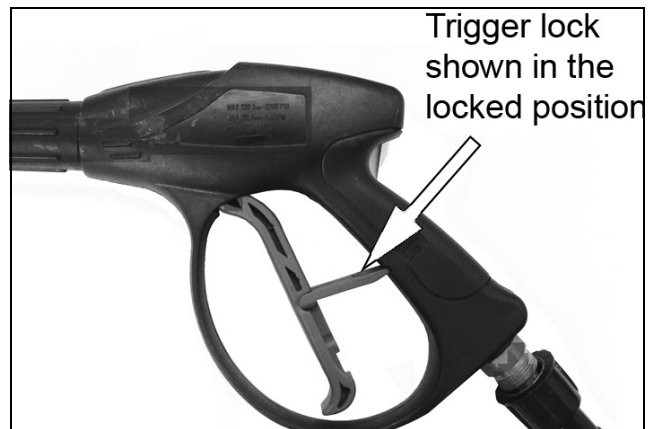

WATER BUTT CONNECTION

This machine has the ability to draw its own water, meaning you can use water not under pressure such as rainwater collected in a water butt.

To do this you must carry out the following procedure.

1. Remove the quick connector from the water inlet.

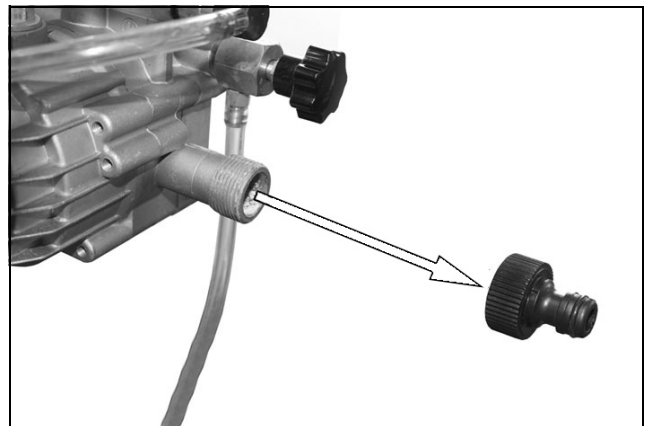

2. Attach the filter to the end of the braided pipe supplied.

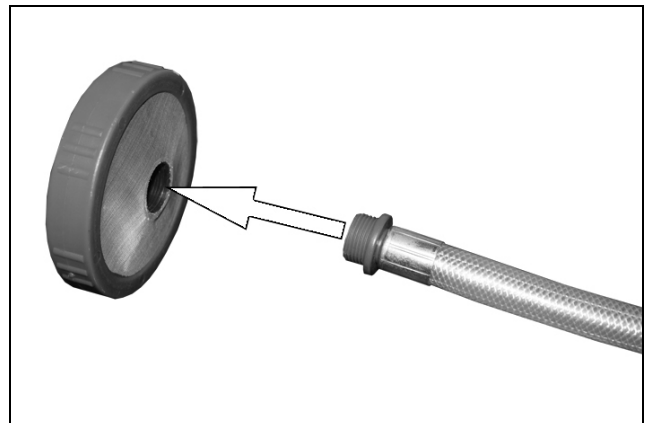

3. Remove the water inlet filter.

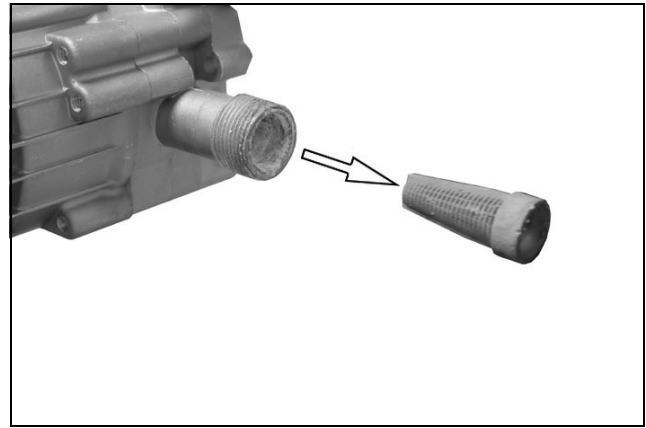

4. Connect other end of the braided pipe to the water inlet.

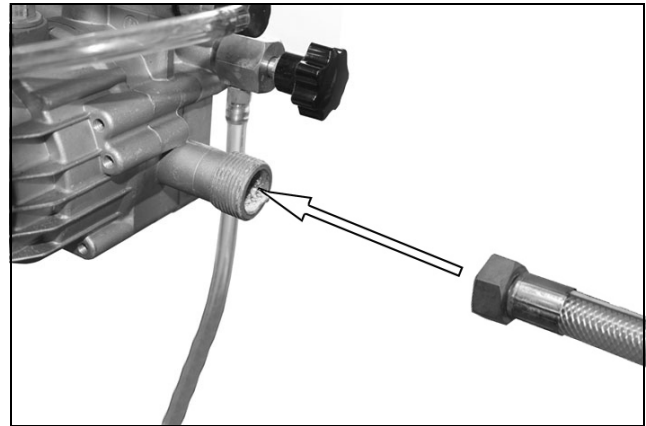

5. Fill the priming bottle with water.

6. Connect the hose from the bottle to the self-suction valve shown.

7. Place the filter into the water source and start the pressure washer, See "Starting your pressure washer" on page 11.

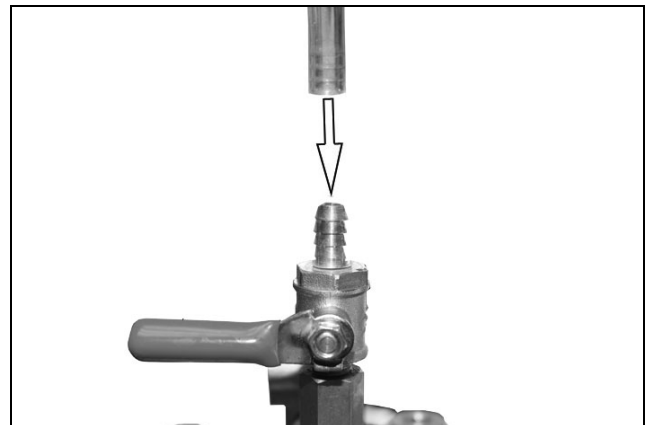

8. Release the exhaust valve.

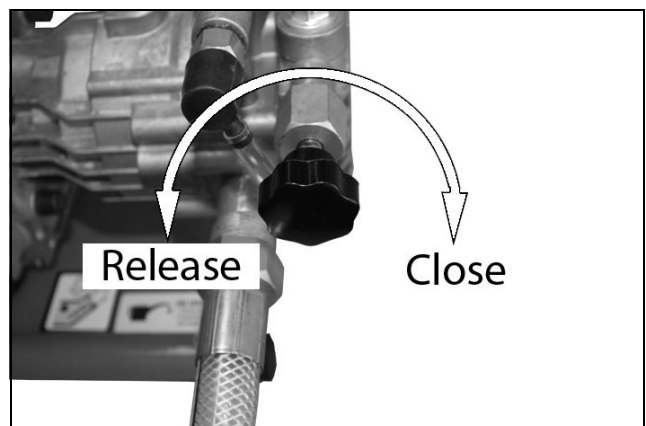

9. Turn the self-suction valve to the on position.

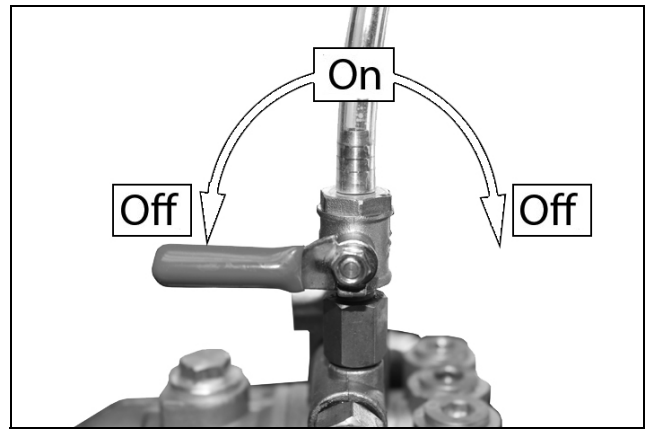

10. Release the trigger lock and pull the trigger.
11. When the water spray is at high pressure, close the exhaust valve and set the suction valve to the OFF position.

NOTE: If the water butt runs out of water, the pressure washer will need to be primed before use by repeating steps 4-10.

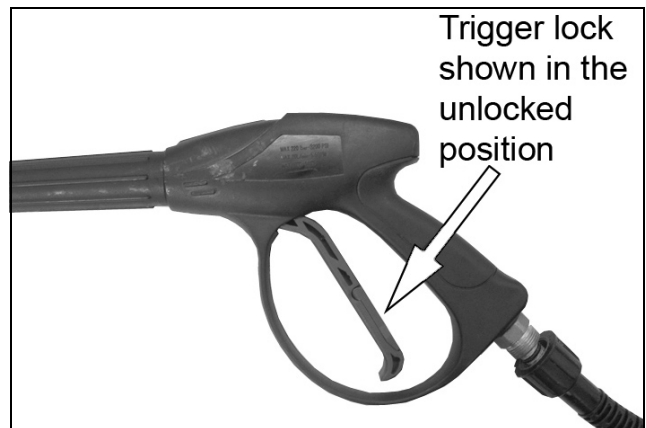

STORAGE

1. Follow the Shutting down procedure on page 18.
2. Disconnect the high pressure hose and drain all water from the hose.
3. Coil the hose and store the gun/lance in the holders located on the side frame of the pressure washer.

STORAGE PROCEDURE

Make sure that the pressure washer has been thoroughly cleaned before storing it in a clean dry place. For long term storage See page 21.

MAINTENANCE

CLEANING THE NOZZLE

1. Switch off the pressure washer and the water supply.
2. Pull the trigger to release any water pressure.
3. Disconnect the lance from the gun assembly.
4. Remove all blockages with the nozzle cleaning tool provided and back flush with clean water.
5. Run water into the end of the lance for 30 seconds to back flush loose particles.
6. Reconnect the lance to the gun assembly and turn on the water.

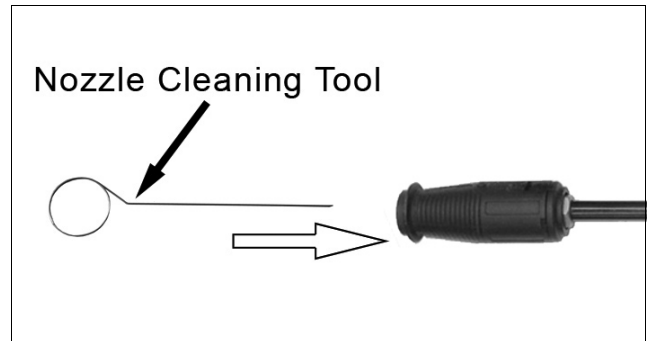

CLEANING THE WATER INLET FILTER

1. Remove the filter from the water inlet of the pump as shown.
2. Clean the filter by flushing both sides with water.
3. Replace the filter into the water inlet.
 - Do not operate without the filter properly installed.

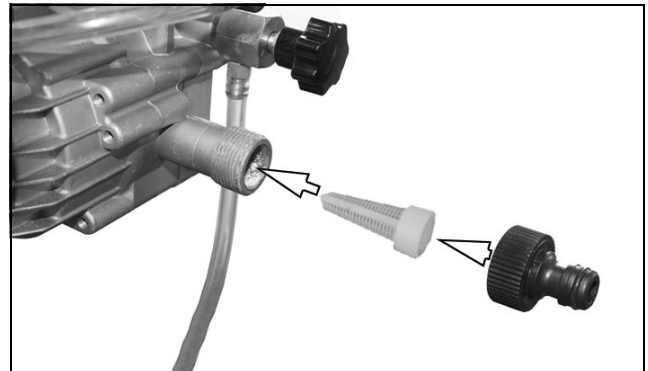

CLEANING THE FUEL STRAINER

Just inside the fuel tank is a fuel strainer, check this periodically and remove any contaminants which may have accumulated.

1. Open the fuel tank cap.



2. Remove the fuel strainer.
3. Flush away any contaminants.
4. Replace the fuel strainer.
 - Do not operate the pressure washer without the fuel strainer properly installed.

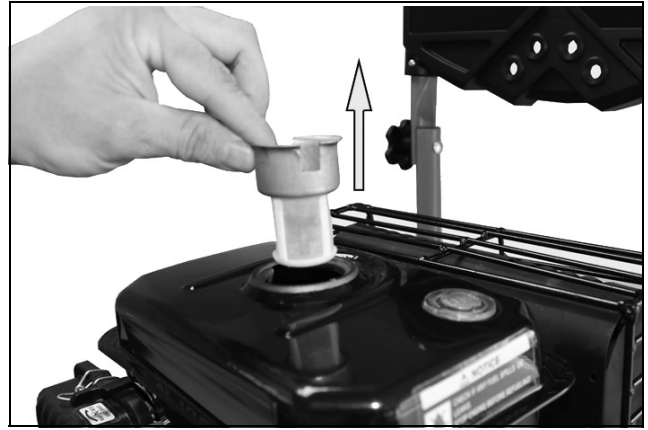

CLEANING THE AIR FILTER

1. Remove the two screws on the air filter cover.
2. Remove the air filter cover
3. Remove the air filter element.
4. Wash it in a solution of warm water and mild detergent.



WARNING: DO NOT USE FLAMMABLE SOLVENTS OR PETROL TO CLEAN THE AIR FILTER

5. Rinse thoroughly and leave it to dry. Once it is completely dry, immerse the filter in clean engine oil and squeeze the filter to remove excess oil.
 - If the air filter is damaged contact CLARKE spare parts department for a replacement.
6. Replace the filter into its original position and refix the air filter cover.

CHANGING THE SPARK PLUGS



CAUTION: ALLOW THE ENGINE TO COOL BEFORE REMOVING THE SPARK PLUG.

1. Remove the spark plug cap from the spark plug.
2. Use the supplied spark plug spanner to remove the spark plug.
3. Remove any carbon that has accumulated around the sparkplug.

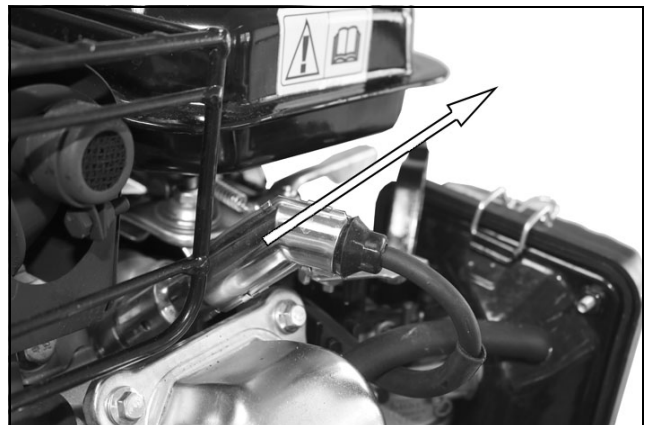

4. Check the overall condition of the spark plug and replace if necessary.
5. Check the spark plug gap (a), it should be between 0.7 and 0.8 mm, adjust if necessary.
6. Reinstall the spark plug and refit the spark plug cap.

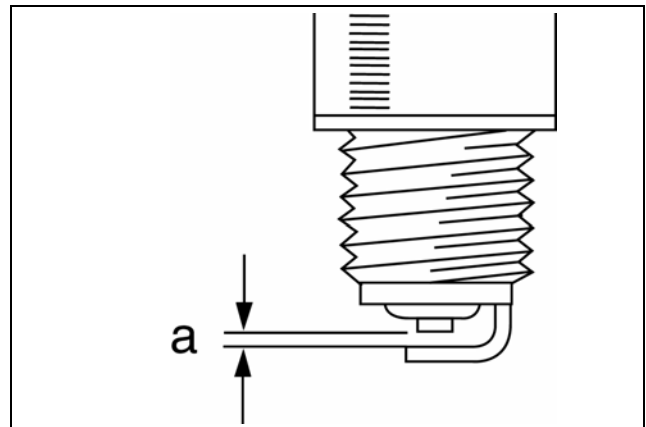

LONG TERM STORAGE

For long term storage;

1. The petrol tank should be drained.
 - Ensure that the engine is cold before draining the tank.
2. Remove the fuel tank cap and use a pump type siphon to drain the petrol into an appropriate, clean container.
 - Do not store petrol for long periods of time.
 - Dispose of excess petrol in an environmentally safe way. Your local recycling centre can advise you on the best method of disposal.
3. After the petrol tank has been drained, start the engine and allow it to use any petrol that may remain in the engine, or fuel pipe.
4. Make sure that the power washer has been thoroughly cleaned before storing it in a clean dry place.

ACCESSORIES

The range of accessories listed below may be purchased from your CLARKE dealer.

ITEM	PART NUMBER
5 Litres Detergent (Traffic Film Remover)	3050821
25 Litres Detergent (Traffic Film Remover)	3050820
5 Litres Wash 'n' Wax	3050815

TROUBLESHOOTING

If the following does not solve your problem contact the CLARKE service dept.

PROBLEM	CAUSE	SOLUTION
Engine will not start (see engine manual for further engine troubleshooting)	No fuel.	Add fuel.
	Low oil.	Add oil.
	Pressure builds up after two pulls on the recoil starter or after initial use.	Squeeze the gun trigger to relieve the pressure.
	Spark plug lead not attached.	Attach the spark plug lead.
	Engine switch is in the OFF position.	Set the engine switch to the ON position.
	Choke lever is set to the on position when the engine is already warm.	Set the choke lever to the OFF (right) position.
	Fuel valve closed.	Open the fuel valve.
Oil leaking at the pump	Oil seals worn.	Have them replaced by your dealer.
	Worn O-rings.	Have them replaced by your dealer.
Lack of pressure (initial use)	Leak in the high pressure hose fitting.	Tighten the fitting, use sealant tape if required.
	Nozzle is obstructed.	Clear the nozzle.
	Water filter screen is clogged.	Remove and clean the filter.
	Air in the hose.	Turn off the engine. Turn off the water supply. Disconnect the water source from the pump inlet and turn on the water source to expel the air from the hose. When all the air has been removed, turn off the water supply and reconnect the hose. Turn on the water supply and pull the trigger to expel any air in the gun/lance.

PROBLEM	CAUSE	SOLUTION
Lack of pressure (initial use) continued	Choke lever is in the ON position.	Set the choke lever to the OFF position.
	Throttle control lever is not set high enough.	Move the throttle control lever to left.
	High pressure hose is too long.	Make sure the high pressure hose is under 100 feet.
Will not draw chemicals	Chemical filter is blocked.	Clean the filter.
	Chemicals being used are too thick.	Dilute the chemicals which should have the consistency of water.
	High pressure hose is too long.	Use a longer supply hose instead of a longer high pressure hose.
	Chemical build up inside the chemical injector.	Have the parts cleaned or replaced by your dealer.
Lack of pressure (after a period of normal use)	Worn seal or packing.	Have them replaced by your dealer.
	Worn or obstructed valves.	Have them replaced by your dealer.
Water leaking from the drain hose	Pump is overheating	This is a safety feature and should be expected. It cools the pump by releasing some of the hot water within the pump and replacing it with fresh 'cool' water.
Water leaking at the pump	Loose connections.	Tighten.
	Piston rings worn.	Have it replaced by your dealer.
	Damaged O-rings.	Have it replaced by your dealer.
	Pump head or tubes damaged from freezing.	Have it replaced by your dealer. See Storage.
Pump pulsates	Nozzle obstructed.	Clear the nozzle.

SPECIFICATIONS

ENGINE	
Engine type	Petrol (unleaded). OHV Single Cylinder 4 stroke forced air cooling
Capacity/displacement:	127 cc
Oil Capacity	0.6 L
Lubrication Grade	SAE10W-30
Fuel Tank Capacity: (Litres)	2.1L
WATER CONNECTION	
Max. Feed Temperature	60 °C
Max. Feed Pressure	3-6 Bar
PERFORMANCE DATA	
Maximum Pump Pressure	180 Bar
Working Pressure	130 Bar
Maximum Water Flow	7 l/min
NOISE & VIBRATION	
Sound Pressure Level LpA	86.7 dB(A)
Sound Power Level LWA	107 dB(A)
Guaranteed Sound Power Level LWA	109 dB(A)
Uncertainty Factor K	2.89
Vibration	4.494 m/s
Uncertainty Factor K	1.5
DIMENSIONS	
Length	590 mm
Width	530 mm
Height	1010 mm
Weight	28.5 kg

COMPONENT PARTS LIST

NO	DESCRIPTION
1	Cross pan head screw M6x40
2	Detergent Tank
3	Inner Hexagon Bolt M8x42
4	Rubber Foot Washer
5	Rubber Foot
6	Frame
7	Locknut M8
8	Flat Washer Ø6
9	Locknut M6
10	Inner Hexagon Bolt M8x45
11	Flat Washer Ø8
12	Hub Cover
13	Wheel Shaft
14	11" Plastic Wheel
15	Clip
16	Spring Wire
17	Baseboard
18	Engine Cushion
19	Engine
20	Locknut M8
21	Hand Wheel
22	Square Neck Bolt
23	Plug
24	Flat Key
25	Leading Sleeve
26	Drain Hose (320mm)
27	Drain Hose (320mm)

NO	DESCRIPTION
28	Flat Washer Ø8
29	Spring Washer Ø8
30	Inner Hexagon Bolt M8x25
31	Lance
32	Gun
33	Overflow Valve Cover
34	Panel
35	Locknut M8
36	Flat Washer Ø5
37	Gun Holder
38	Flat Washer Ø5
39	Spring Washer Ø5
40	Cross Pan Head Screw M5x16
41	Hose
42	Hose Strap
43	Handle Foam
44	Cross Pan Head Screw M5x42
45	Nozzle Grommet
46	Injection Hose
47	Bottle Cap
48	Bottle
49	Bottle Frame
50	Cross Pan Head Screw M5x40
51	Bottle Holder
52	Locknut M8
53	Detergent Tank Cap

DECLARATION OF CONFORMITY



DECLARATION OF CONFORMITY

This is an important document and should be retained.

We hereby declare that this product(s) complies with the following legislation: The following standards have been applied to the product(s):

Noise Emission in the Environment by Equipment for use Outdoors Regulations 2001

EN ISO 3744:1995, EN 60335-1:2012/A11:2014, EN 60335-2-79:2012, EN ISO 12100:2010,

The Electromagnetic Compatibility Regulations 2016

EN ISO 14982:2009, IEC 62321-3-1:2013, IEC 62321-4:2013+AMD1:2017,

The Supply of Machinery (Safety) Regulations 2008

IEC 62321-5:2013, IEC 62321-6:2015, IEC 62321-7-1:2015, IEC 62321-7-2:2017,

The Restriction of the Use of Certain Hazardous Substances in Electrical and Electronic Equipment Regulations 2012

IEC 62321-8:2017, ISO 17075-1:2017

The technical documentation required to demonstrate that the product(s) meet(s) the requirement(s) of the aforementioned legislation has been compiled and is available for inspection by the relevant enforcement authorities.

The UKCA mark was first applied in: 2023

Manufacturer: Clarke International Ltd, Hemnall Street, Epping, Essex, CM16 4LG, United Kingdom

Notified Body: N/A

Product Description: Power Washer

Assessment Procedure: Annex V of above noise legislation

Model Number(s): TIGER 2600B

Measured LWA: 99.3 dB

Serial/Batch Number: Refer to product/packaging label

Guaranteed LWA: 102 dB

Document Holder: Alan Pond

Signed:

J.A Clarke

Date of Issue: 11/09/2023

Director

TIGER 2600B UKCA Clarke DOC 091123

Page 1 of 1



DECLARATION OF CONFORMITY

This is an important document and should be retained.

We hereby declare that this product(s) complies with the following legislation: The following standards have been applied to the product(s):

2000/14/EC

Outdoor Noise Directive

EN ISO 3744:1995, EN 60335-1:2012/A11:2014, EN 60335-2-79:2012, EN ISO 12100:2010,

2014/30/EU

Electromagnetic Compatibility Directive

EN ISO 14982:2009, IEC 62321-3-1:2013, IEC 62321-4:2013+AMD1:2017,

2006/42/EC

Machinery Directive

IEC 62321-5:2013, IEC 62321-6:2015, IEC 62321-7-1:2015, IEC 62321-7-2:2017,

2011/65/EU

Restriction of Hazardous Substances (RoHS) Directive

IEC 62321-8:2017, ISO 17075-1:2017

The technical documentation required to demonstrate that the product(s) meet(s) the requirement(s) of the aforementioned legislation has been compiled and is available for inspection by the relevant enforcement authorities.

The CE mark was first applied in: 2008

Manufacturer: Clarke International Ltd, Fitzwilliam Hall, Fitzwilliam Place, Dublin 2, Republic of Ireland

Notified Body: N/A

Product Description: Power Washer

Assessment Procedure: Annex V of above noise legislation

Model Number(s): TIGER 2600B

Measured LWA: 99.3 dB

Serial/Batch Number: Refer to product/packaging label

Guaranteed LWA: 102 dB

Document Holder: Alan Pond

Signed:

J.A Clarke

Date of Issue: 11/09/2023

Director

TIGER 2600B CE Clarke DOC 091123

Page 1 of 1

A SELECTION FROM THE VAST RANGE OF

Clarke®

QUALITY PRODUCTS



AIR COMPRESSORS

From DIY to industrial, Plus air tools, spray guns and accessories.

GENERATORS

Prime duty or emergency standby for business, home and leisure.

POWER WASHERS

Hot and cold, electric and engine driven - we have what you need

WELDERS

Mig, Arc, Tig and Spot. From DIY to auto/industrial.

METALWORKING

Drills, grinders and saws for DIY and professional use.

WOODWORKING

Saws, sanders, lathes, mortisers and dust extraction.

HYDRAULICS

Cranes, body repair kits, transmission jacks for all types of workshop use.

WATER PUMPS

Submersible, electric and engine driven for DIY, agriculture and industry.

POWERTOOLS

Angle grinders, cordless drill sets, saws and sanders.

STARTERS/CHARGERS

All sizes for car and commercial use.

PARTS & SERVICE: 0208 988 7400

Parts Enquiries
Parts@clarkeinternational.com

Servicing & Technical Enquiries
Service@clarkeinternational.com

SALES: UK 01992 565333 or Export 00 44 (0)1992 565335

Clarke INTERNATIONAL Hemnall Street, Epping, Essex CM16 4LG
www.clarkeinternational.com